

SHEET METAL ROOF APPLICATIONS

Roof Curbs

Ventilators

Air Handlers

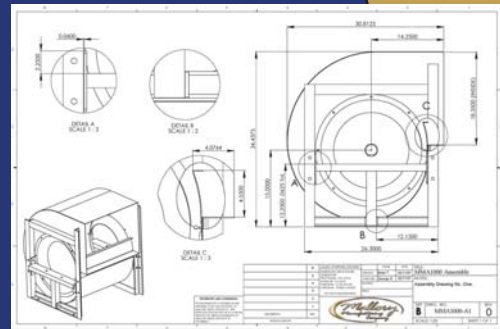
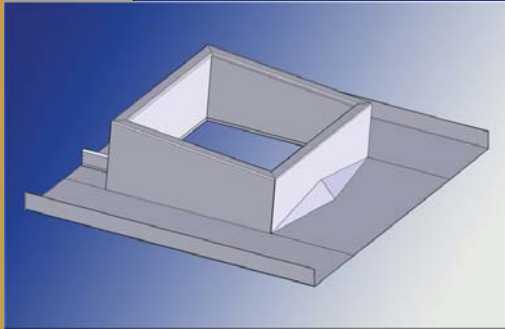

QUALITY

SERVICE

The choice to make when superior quality and service count.





Mallory Manufacturing Company is a fast growing U.S. owned and operated manufacturer in operation since 1989. Our skilled employees operate a state-of-the-art 50,000 square foot manufacturing facility. Mallory Manufacturing is committed to continually improve its processes and customer satisfaction.

Mallory Manufacturing specializes in developing and manufacturing high precision products. We manufacture quality products including, but not limited to, a wide array of roofing applications as well as parts & assemblies manufactured and designed to specific customer specifications.

Mallory Manufacturing has developed and implemented the Quality System outlined by ISO 9001-2000. Our quality policy ensures that products, standards, and services meet the manufacturing and safety requirements demanded by the industries served. Our quality system is considered by Mallory Manufacturing management to be an integral and essential part of the company's operations.

Our quality policy was implemented to provide superior value while producing quality products that satisfy the needs and expectations of Mallory Manufacturing's customer base. We maintain a strong commitment to continually improve the effectiveness of Mallory Manufacturing's quality management system.

Mallory Manufacturing's quality policy has been communicated to each and every employee; including management. Employees understand the quality management systems purpose and work to achieve quality commitment through out the organization. Mallory Manufacturing's quality management system reflects the organizations total commitment in achieving the needs of our customer base efficiently and safely.



ROOF CURBS

Roof Curbs are raised frames used to structurally mount rooftop equipment such as HVAC units, exhaust fans, skylight, etc. Curbs also provide a level mounting point for mechanical equipment and provide a seal from outside elements by utilizing the curbs internal flange to interlock with the roof paneling. This insures years of protection and stability for both the mechanical equipment and the roof itself.

VENTILATORS

Ventilation is the intentional movement of air from the outside of a building to the inside and vice-versa. It aids in providing fresh air in a building while removing hot, stale air. Ventilation air is necessary to dilute odors and limit the concentration of CO2 and airborne pollutants providing acceptable indoor air quality.



AIR HANDLERS

Air handlers are used as part of a heating, ventilating, and air-conditioning HVAC system. Our air handlers contain blowers, heating and/or cooling elements, filter racks or chambers, sound attenuators, and dampers.

Our air handlers deliver comfortable conditioned air throughout your building. They work to circulate cool air in the summer or, when ordered with a heating system, circulate warm air in the winter and cool air in the summer.



Mallory Manufacturing manufactures all roof curbs, ventilators & air handler systems to meet all your requirements and needs. Mallory manufactures all of its equipment to the highest industry standards and specifications.

MANUFACTURING CAPABILITIES

What ever your requirement, Mallory Manufacturing has the state of the art computer controlled equipment to ensure your parts are manufactured to the highest quality and precision.

The state of the art equipment at our disposal allows us to fabricate high-precision and high quality parts for a wide variety of applications.

Our facility is over 50,000 square feet, allowing us the capability to handle any job - from the smallest to the largest customer requirements. Mallory Manufacturing Company's extensive facility and highly skilled fabricators enable us to manufacture all customer requests with great efficiency, the most economical pricing, and fast delivery.

With over 50 years experience in the fabrication of metal parts, you can count on Mallory Manufacturing Company to deliver exactly what you ordered.

In addition, Mallory Manufacturing Company offers full-service, high quality design and engineering services at our facility. We support your product vision by utilizing highly proficient engineers, while employing the latest technologies and efficient methods for product optimization and project acceleration. More than that, we are responsive and truly listen to your needs in order to fully understand your vision and goals.



Mallory Manufacturing Company also offers a variety of high quality custom finishing to the parts we manufacture. Our services include anodizing, powder and liquid coating services.

When quality and service count - You can count on Mallory Manufacturing Company!





CUSTOM PARTS

AIR HANDLERS

Mallory Manufacturing Company

2655 Airport Rd.
Santa Teresa, NM 88008

575.589.2130 Tel
800.388.1031 Toll
575.589.2608 Fax

www.mallorymetal.com
info@mallorymetal.com

Mallory Manufacturing Company is the choice to make when superior quality and precision count. We pride ourselves in assuring our customers the best quality product, with the least amount of lead time.

When quality and service count - You can count on Mallory Manufacturing Company!

ROOF CURBS

VENTILATORS

SALES AND CUSTOMER SERVICE, USA : (800)388-1031

INTERNATIONAL SALES : 001-575-589-2130

www.mallorymetal.com
info@mallorymetal.com